

RACE
APPLICATION
ONLY

860

2011 GM DURAMAX 6.6L
4" CAT BACK SINGLE SYSTEM

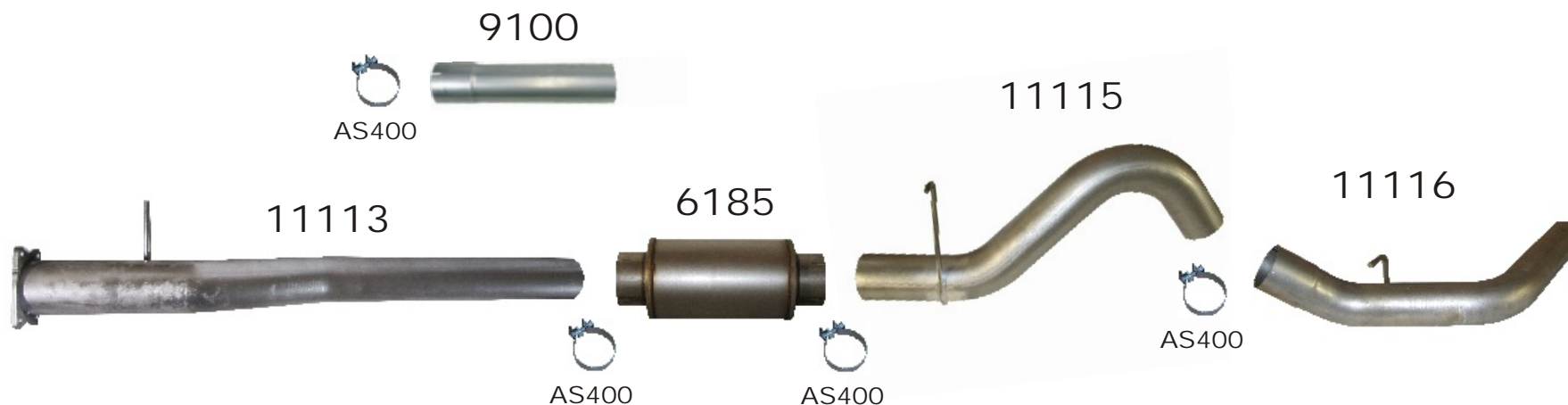

- 1-11113
- 1-9100
- 1-6185
- 1-11115
- 1-11116
- 4-AS400

FLO~PRO
PERFORMANCE EXHAUST

PICKED BY: _____



**WARNING: BEFORE YOUR BEGIN, VERIFY
THAT YOU RECEIVED THE RIGHT KIT &
EACH PART LISTED ON THE REVERSE PAGE**



**KIT # 860
2011 CHEV DURAMAX LML
4" CATBACK SINGLE SYSTEM**

For race applications only.

REMOVAL OF ORIGINAL SYSTEM

1. Unbolt the flanges fastening the downpipe and the DPF/tailpipe assembly.
2. Remove all factory bungs and airlines on Diesel Particulate Filter, tie-strap them to the frame of the truck or take them off at the clip connection.
3. Spray the hangers with WD-40 and then pry hangers from the rubber and remove the DPF/tailpipe from truck. You may need to cut the tailpipe to aid in the removal (**Note: A sawzall or hacksaw is the preferred method of cutting exhaust**). If you do not want to cut the tailpipe, lift the rear end of the truck until the tires are almost hanging freely. Pull assembly towards the front of truck.

Notes: - *Make sure to put clamps on connections before connecting pipes.*
- *Snug the clamps down so they will hold the pipe but the pipe can still be moved with some effort.*

INSTALLATION INSTRUCTIONS

1. Install pipe #11113 by attaching the two flanges together using the OEM fasteners.
For shorter wheel bases, you will need to cut it. For Crew Cab Long Box models pipe #9100 will be needed (Note: be sure to allow for tubing connections approx. 4").
2. Install muffler, over the axle pipe and tailpipe placing hangers onto OEM rubber insulators. Snug all the clamps down so they will hold the pipe but the pipe can still be moved with some effort.
3. With all the pipes mounted loosely, adjust the new FLO-PRO system for clearance and appearance. Evenly tighten all bolts and clamps working your way to the back of the truck.

www.flopro.com

Technical Support: 1 800 762 4286 or email, techsupport@flopro.com